

ELECTROTECHNICAL EQUIPMENT



LIST OF CONTENTS

LED indicator lamps 3

The ULZS(I) electronic glow-starter 7

The S-ID and S-IDX contactors

The S-IR, K-ERS and K-ERB thermal relays 11

LV current transformers

MV current and voltage transformers 15

LED indicator lamps



Introduction

LED indicator lamps are used for indicating the condition of electric circuits, devices and technological processes. They replace incandescent and neon lamps. Thanks to semiconductor technology, the lamps' lifetime has been extremely prolonged. Predicted working time of a semiconductor structure in an electric circuit is at least 100000 hours.

Construction and operation principles

Each lamp has a bowl sized 5, 10 or 20mm set in a black plastic threaded casing with a nut for fitting the lamp in a hole. Normally, the diodes are fitted with 0.33m cables. On a Customer's individual request we fit the lamps with cables of arbitrary length or with connectors. The AC version of the lamp has an internal half-wave rectifier and can be energised with DC voltage at 1/2 the value of nominal AC voltage, except from 20mm lamps which have a Graetz circuit (diode bridge) in their structure allowing AC and DC feeding. DC lamps have to be connected to a supply minding the polarity and cannot be used in AC circuits. The rectifying diode used in the lamps ensures surge protection to up to 600V.

Types of indicator lamps:

The indicator lamps are available in three sizes:

– diameter 5 mm (fig. 1) – product reference *mini*



– diameter 10 mm (fig. 2) – product reference *medium*



– diameter 20 mm (fig. 3) – product reference *gigant*



The lamps are manufactured for voltages from 2.5V to 400V, through non-typical voltages such as 63V, 110V etc., AC and DC, all of which has to be specified when ordering.

Indicator lamps versions:

– one-colour lamps

Manufactured in each of the three sizes for voltages from 2.5 to 400V, DC or AC. Available in the following colours: red (R), green (G), yellow (Y), orange (O), blue (B), white (W).

– two-colour lamps

Two-colour lamps are manufactured in each of the three sizes, in the following colour combinations: red-green (R/G), red-yellow (R/Y), green-yellow (G/Y) and other (also using: blue, orange and white). The diodes have three cables led out; two corresponding to the colours of illumination and the third one connected to the common electrode (common cathode or anode version has to be identified while ordering).

– multi-colour and flashing lamps

The $\varnothing 10$ and $\varnothing 20$ lamps are also available in a multi-colour or flashing version for voltage from 9 to 230V, AC or DC. Important: the lamps cannot luminesce in more than one colour at a time, but we can manufacture mixed-colour lamps for Customers' individual requests.

– connector lamps (suitable for soldering of feeding wires)

The version of lamps with connectors instead of standard wires is only available in sizes $\varnothing 10$ and $\varnothing 20$. The type of connectors used is J 2.8

Technical parameters

Operating voltage: 2,5 V, 12 V, 24 V, 63 V...400 V AC lub DC.

Power consumption: 1,0 W

Protection degree: IP20

Connection : LGY 0,5 mm² cable or connectors

Feeding cables colours† **One-colour lamps:**

– 230 V AC – cables colours corresponding to the colour of luminescence

– 230 V DC – red and black

– 24 V AC/DC – red and green

– 12 V AC – red and blue

– 110 V AC – red and blue

– 400 V AC – black cables

Two-colour lamps:

– 230 V – cables colours corresponding to the colour of luminescence + black cable

– 24 V AC/DC – cables colours corresponding to the colour of luminescence + brown cable

– BA9S casing lamps (fig. 4)

Bayonet cap lamps in BA9S casing are available for voltages from 12 to 230V AC/DC, in following colours: green (G), red (R), yellow (Y), blue (B), white (W), orange (O). The source of light in these lamps is a highly efficient LED diode emitting monochrome light with a specific wavelength. Constant luminous flux through the whole lifetime allows proper adjustment of light emission angle and luminescence intensity.

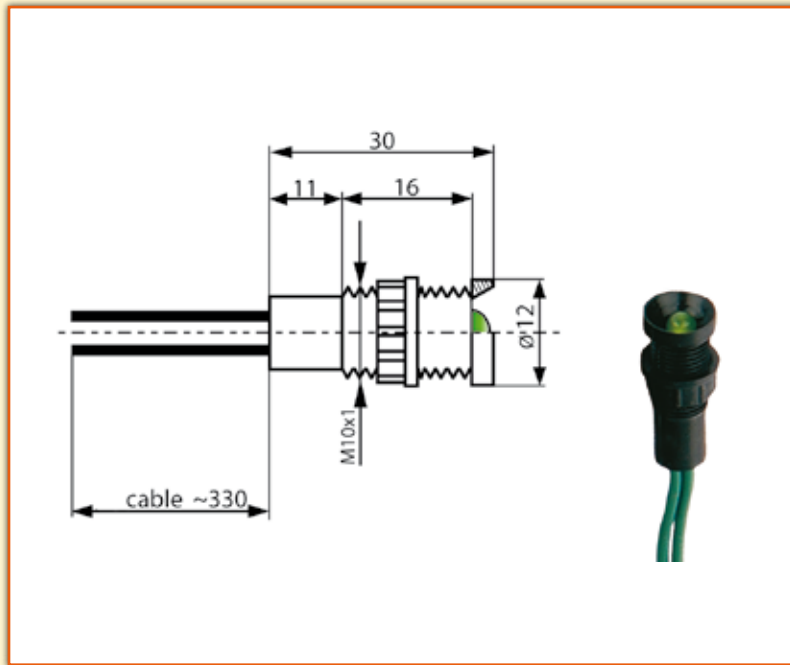

Fig. 1. Mini indicator lamp.

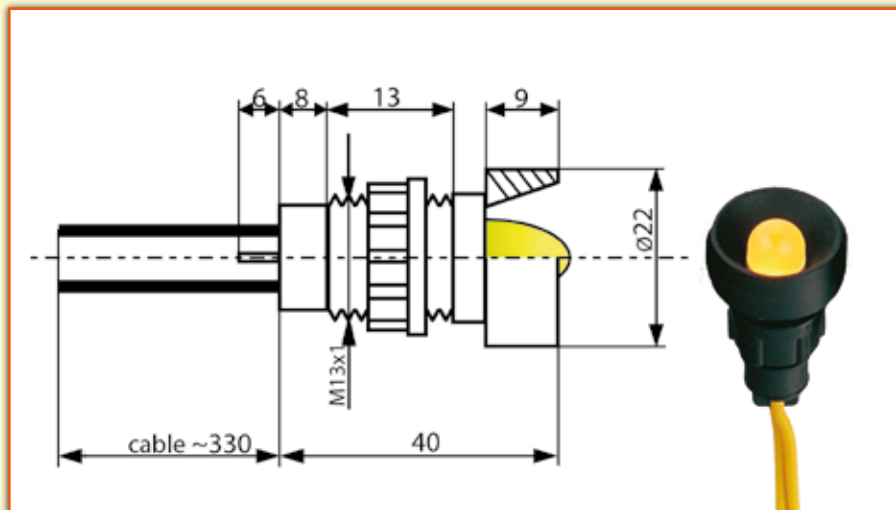

Fig. 2. Medium indicator lamp.

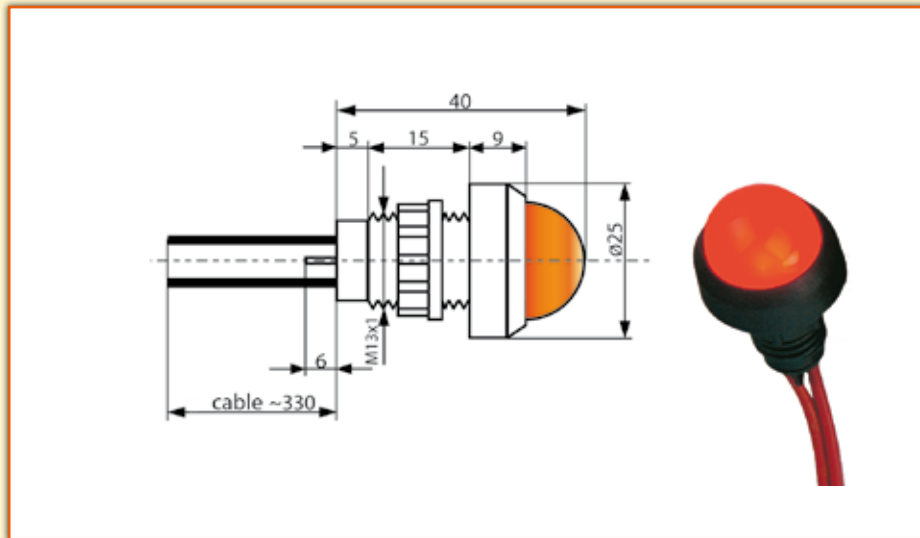

Fig. 3. Gigant indicator lamp.

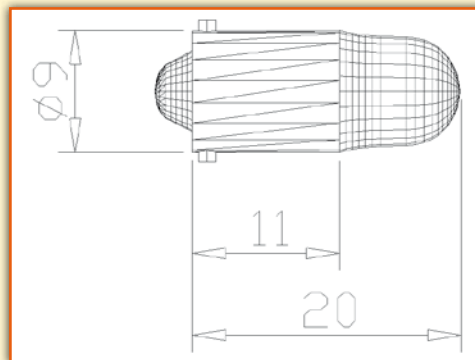

Fig. 4. BA9S bayonet cap indicator lamp.

The ULZS(I) electronic glow-starter



Introduction

The ULZS(I) electronic starter is designed for glow starting high-pressure sodium-discharge and metal-halide lamps from 35 to 400 (1000) W.

Construction

The device is enclosed in an aesthetic cylindrical plastic casing resistant to corrosion and mechanical damage. There is a LED diode built into the starter for instant location of faults in the glow start circuit of a lamp. The diode flashing indicates the frequency at which high-voltage impulses are being generated, while continuous luminescence means proper operation of the glow start and ballast circuits.



Operation principles

The glow-starter is mounted in its place using a M6 nut at the base of it. It can be connected to a lamp in series or in series-parallel minding phase and neutral connections. The device guarantees glow start of cold as well as hot lamps in less than 5s. After starting a lamp the glow start circuit imposes no additional load as it is automatically disconnected from the lamps' circuit to minimise power losses.



Types of the glow-starters:

- **UZLS – 1** for parallel connection to 100-1000W sodium-discharge lamps
- **UZLS – 1/A** for parallel connection to 35-70W sodium-discharge lamps
- **UZLS – 2** for series-parallel connection to 100-400W sodium-discharge lamps
- **UZLSI – 3** for series-parallel connection to 100-1000W metal-halide and sodium-discharge lamps
- **UZLSI – 4/A** for series-parallel connection to 35-70W metal-halide and sodium-discharge lamps
- **UZLSI – 4** for series-parallel connection to 100-400W metal-halide and sodium-discharge lamps

| Type of lamp | Power[W] | | |
|------------------------------------|---------------------------|--|-----------------------------------|
| | 35 – 70 | 100 – 400 | 600 – 1000 |
| Sodium-discharge lamps up to 4.5kV | UZLS – 1/A UZLSI – 4/A | UZLS – 1 UZLS – 2 UZLSI – 3 UZLSI – 4 | UZLS – 1 UZLS – 2 UZLSI – 3 |
| Metal-halide lamps up to 4.5kV | UZLSI – 4/A | UZLSI – 3 UZLSI – 4 | UZLSI – 3 |



Usage advantages:

- Resistant to corrosion and mechanical impacts.
- Small dimensions.
- Fast glow start of cold and hot lamps.
- Easy to fit into existing installations.
- After starting a lamp the glow-starter isolates the glow start circuit and signals it with the LED.
- Highly repeatable parameters within series of the product.
- Current drawn by the device 0.6mA.

Technical parameters:

| | |
|---------------------------------------|---|
| Supply voltage | 230 V \pm 10 % |
| Frequency | 50 Hz |
| Operating temperature | -30°C \div +80°C |
| Length of cable to be uninsulated | 8 mm |
| Withstand punch-through | >20 kV |
| Sodium-discharge lamp glow start time | <5 s |
| Fault-free operation time | min. 3 years |
| Weight | 52 g |
| Firing impulse characteristic curve | sinusoidal, amplitude 3000 – 4500 (5500) V |

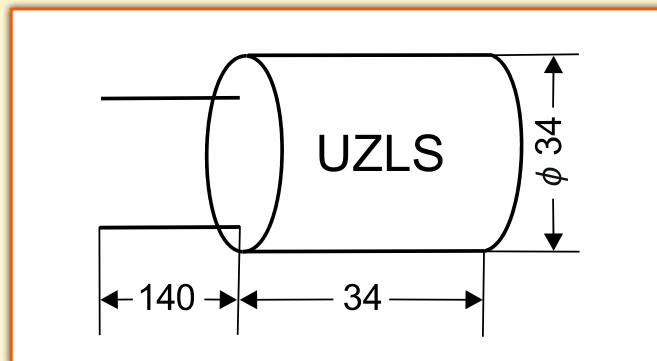

Fig. 1. Glow-starters for parallel connection to high-pressure lamps.

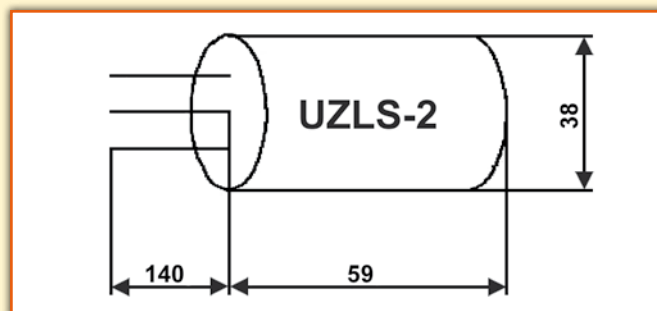

Fig. 2. Glow-starters for series-parallel connection to high-pressure lamps.

CONNECTION DIAGRAM

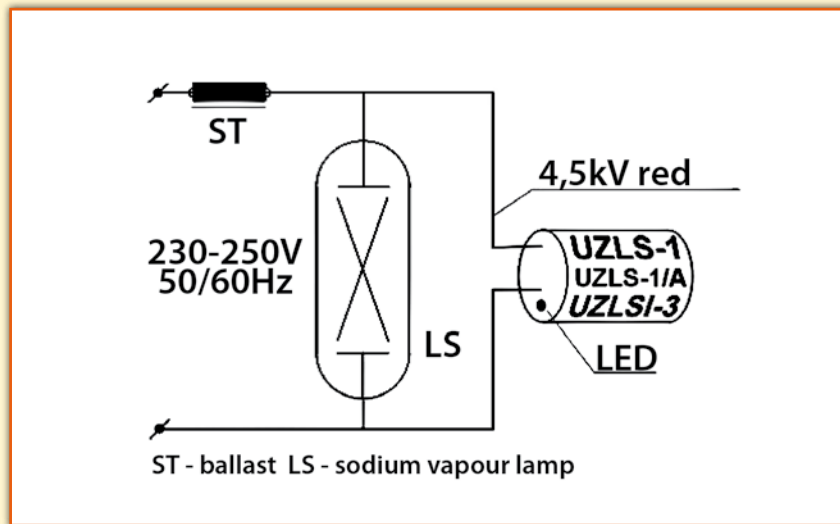

Fig. 3. Glow-starters for parallel connection to high-pressure lamps.

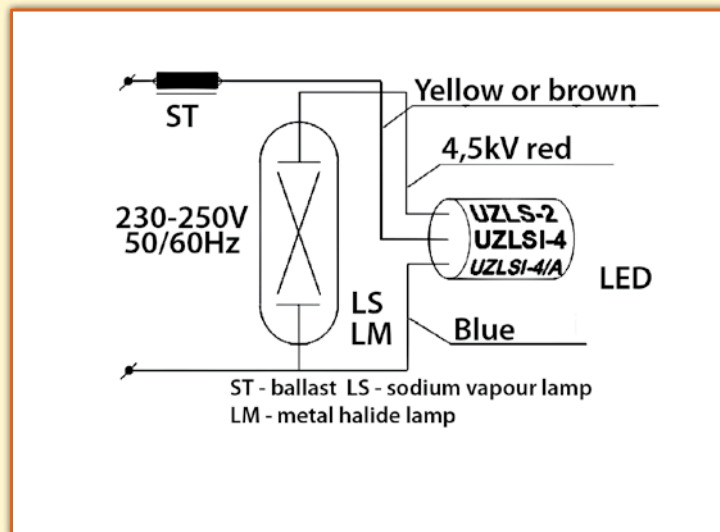
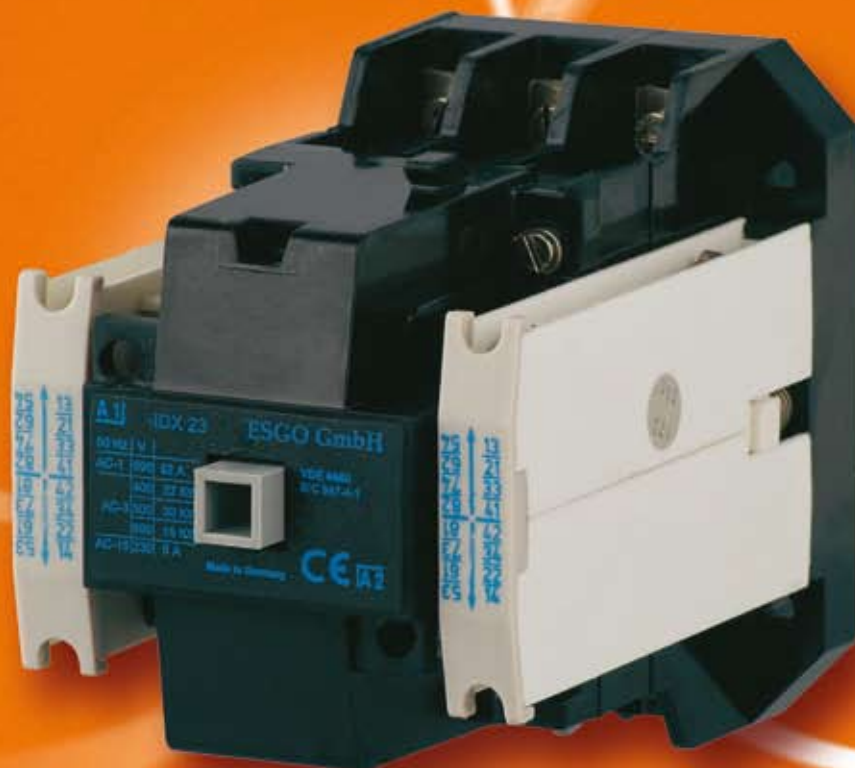

Fig. 4. Glow-starters for series-parallel connection to high-pressure lamps.

The S-ID and S-IDX contactors

The S-IR, K-ERS and K-ERB thermal relays



Introduction

Contactors are remotely controlled electric switching devices. They find their use in low-voltage installations, distribution boards, control devices and capacitor banks. Most widely they are used for switching in three-phase AC circuits, but they can be used in DC circuits as well. The ID contactors are suitable for direct switching of squirrel-cage motors and for use as starter contactors with other kinds of motors. The IDX contactors are used for switching of power capacitors. Currently the ID and IDX symbols are replaced by the S-ID and S-IDX respectively. The dimensions remain the same as in the contactors manufactured in former East Germany. Their manufacturer has improved the durability of heavy-current contacts and eliminated asbestos from the contactors' structure. The whole series has the GL attest (Germanischer Lloyd) and conforms to the DIN VDE 0660 and IEC 947 standards.

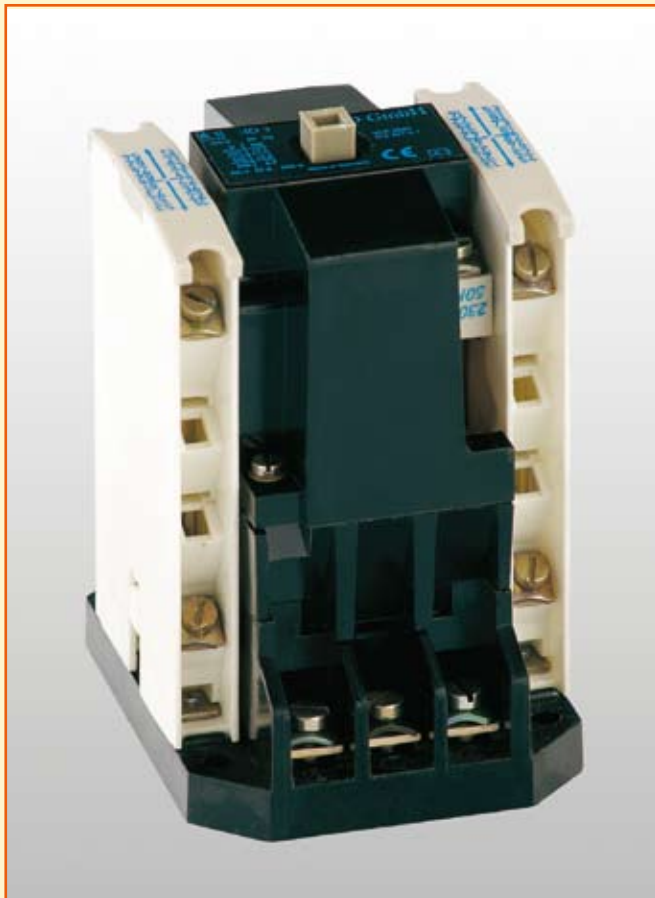

Construction

Series S-ID and S-IDX contactors are of compact, modular design. The contacting section and the electromagnets are hidden deep inside the contactor's structure, which reduces vibration and ensures mechanical reliability. The auxiliary contacts are placed beside the heavy current switching module. The casing allows easy access to main and auxiliary current connection points, and all service required to be carried out without removing the contactor from its place. The part projecting out from the contactor's body indicates position of the contacts and can be used for manual switching.

Operation principles

An untypical design solution, which is the use of special washers, allows fast and reliable connection to control and heavy-current cables. Specially shaped, self-lifting washers ensure correct and easy fastening. There are no maintenance works required when using the contactor in normal conditions, except from periodical inspections on the wear of the main contact, dependingly on the load and the frequency of switching. Replacement of the moving and the fixed contacts, or the arc-extinguishing chamber does not require the device to be disassembled completely, as it is enough just to remove the switching module. The coil likewise needs no specialistic tools to get replaced.



Usage advantages:

- contact provided by the system of two coils: the driving and the sustaining coil,
- surge arrester built into the frame of the coil to eliminate damage from surges in other electric devices,
- minimised power losses in the switching system,
- controllable voltage range increased from 0.675 to 1.35kV.

Standard

DIN VDE 0660, IEC 947

Additional equipment

Type S-IR thermal protection can be connected directly to the ID and IDX contactors, as well as additional components to dampen the vibration caused by disconnection of the driving coil: the ZX 20 and the ZX 25. They are available in nominal voltages of up to 230V. The ZX 20 is to be used with AC and the ZX 25 with DC contactors. We also supply the complete choice of spare parts including: main contacts, auxiliary contacts, coils, etc.

Types of contactors and technical parameters

| Contactor type | S – ID 01 | S – ID 1 | S – IDX 23 | S – IDX 31 | S – IDX 41 | S – IDX 43 | S – ID 6 | S – ID 7 |
|--|----------------------------|----------------------------|----------------------------|--------------------------|--------------------------|-------------------------------|--------------------------|-----------------------------|
| Insulation voltage AC [V] | 750 | 750 | 750 | 750 | 750 | 750 | 750 | 750 |
| Operating current AC – 1 690 V [A] AC – 3 400 V [A] | 25 16 | 32 25 | 52 45 | 80 63 | 116 90 | 116 110 | 180 160 | 250 250 |
| Operating voltage AC – 3 230 V [KW] 400 V [KW] 500 V [KW] 690 V [KW] | 4,5 8 10,6 7,5 | 7,5 12,5 16,6 8,7 | 15 22 30 15 | 18,5 30 45 22 | 30 45 55 30 | 30 55 55 37 | 50 85 112 111 | 75 132 140 148 |
| Thermal current I_{th} | 30 | 40 | 60 | 90 | 130 | 130 | 200 | 300 |
| Control voltage AC [V] DC [V] | 24...500 24...220 | 24...500 24...220 | 24...500 24...220 | 24...500 24...220 | 24...500 24...220 | 24...500 24...220 | 24...500 24...220 | 24...500 24...220 |
| Controlled power capacitors: 230 V [Kvar] 400 V [Kvar] 500 V [Kvar] 690 V [Kvar] | 4,0 7,5 10 13 | 4,0 7,5 10 13 | 4,0 7,5 10 13 | 13 25 32 43 | 23 40 52 69 | 23 40 (50) 52 69 | 33 57 52 69 | 57 100 130 173 |
| Thermal relay | S – IR 1 | S – IR 1 | S – IR 1 S – IR 2 | S – IR 3 | S – IR 4 | S – IR 4 | K – ERB K – ERS | K – ERB K – ERS |
| Dimensions (W x H x D) | 67 x 80 x 110 | 67 x 85 x 110 | 75 x 95 x 120 | 87 x 110 x 140 | 95 x 125 x 154 | 95 x 125 x 154 | 160 x 190 x 140 | 160 x 205 x 140 |

The S-IR, K-ERB and K-ERS thermal relays

Wherever there are circuits switched by contactors instead of switches, it is possible to use single-pole thermal relays. In crane switchboards for example, where crane motors often have only a single- or two-pole protection, it is possible to switch off the main breaker even when just one relay reacts. In general, thermal relays are to protect motors from thermal overload caused by too high current intake. The S-IR, K-ERB, K-ERS are modern relays conforming to the DIN VDE 0660 and the IEC 947. They can be fixed directly to compatible S-ID(X) contactors or mounted beside them on their own by using a special adapter.

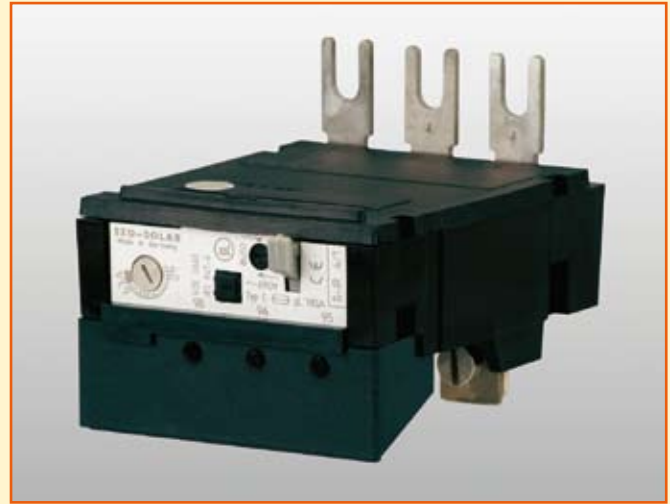

Construction and operating principles

The thermal relays consist of the driving and the contacting section. Bimetal strips heated by a current flow bend when overheated and release the disconnecting system. This opens the relay control current circuit. Type S-IR relays combined with the S-ID(X) contactors are used for control of heavy-current circuits. The K-ERB thermal relays protect electric machinery against overloads during continuous operation, while the K-ERS relays against short circuits.

Types of thermal relays:

| Thermal relay | Contactor | Regulation range | | | |
|---------------|------------|------------------|-----------------|---------------|----------------|
| S – IR 1/1 | S – ID 01 | 0,25 – 0,43 | 1,60 – 2,70 | 10,50 – 16,80 | |
| | S – ID 1 | 0,40 – 0,68 | 2,50 – 4,20 | 16,00 – 25,00 | |
| | S – IDX 21 | 0,64 – 1,10 | 4,00 – 6,60 | | |
| | S – IDX 23 | 1,00 – 1,70 | 6,40 – 10,50 | | |
| S – IR 2/1 | S – IDX 21 | 6,40 – 10,50 | 16,00 – 25,00 | | |
| | S – IDX 23 | 10,00 – 16,00 | 25,00 – 40,00 | | |
| S – IR 3/1 | S – IDX 31 | 6,40 – 10,00 | 16,00 – 25,00 | 40,00 – 63,00 | |
| | | 10,00 – 16,00 | 25,00 – 45,00 | | |
| S – IR 4/1 | S – IDX 41 | 6,40 – 10,00 | 16,00 – 25,00 | 40,00 – 63,00 | 80,00 – 110,00 |
| | S – IDX 43 | 10,00 – 16,00 | 25,00 – 45,00 | 55,00 – 80,00 | |
| K – ERB 1 | S – ID 6 | 6,00 – 10,00 | 16,00 – 25,00 | | |
| | S – ID 7 | 10,00 – 16,00 | | | |
| K – ERB 2 | S – ID 6 | 25,00 – 40,00 | 63,00 – 100,00 | | |
| | S – ID 7 | 40,00 – 63,00 | 100,00 – 160,00 | | |
| K – ERB 3 | S – ID 6 | 160,00 – 250,00 | 400,00 – 630,00 | | |
| | S – ID 7 | 250,00 – 400,00 | | | |

LV current transformers

MV current and voltage transformers



Introduction

The low-voltage current transformers are used for measuring and protection in electric equipment with the highest permissible voltage of 0.72kV or 1.2kV and frequency of 50-60Hz. The CT's can operate in temperatures from -25°C to 50°C, in both normal and difficult operating conditions (such as: ocean-going ships, mining or chemical industry). They are manufactured in accuracy class 0.2; 0.5; 1; 3 and 5, as cable or busbar mounted depending on the type. The CT's in accuracy class 0.2 and 0.5 can be verified as measuring instruments.

Construction

The low-voltage CT's are single-phase, low-power transformers working in conditions similar to short circuit and converting the current flowing in the primary circuit into secondary circuit current meeting the requirements of an accuracy class. All types of the current transformers are enclosed in slow-burning plastic casing resistant to mechanical impact.

Current transformers types

Twelve Electric offers broad selection of low-voltage current transformers manufactured by ABB Przasnysz and Polcontact. They are available with different current ratio, accuracy class and in a wide range of power.



Current transformers versions:

1. Polcontact's low-voltage current transformers:

– series **ELA** current transformers manufactured with round apertures for different sizes of cable or with primary winding.

| Type | Aperture size | Notes | CT width |
|-----------------|--------------------------|--|----------|
| ELA 0 | diameter 16 or 22 mm | | 40 mm |
| ELA 1 W – 20 | with primary winding | | 75 mm |
| ELA 1 | diameter 22, 31 or 41 mm | with dual range of primary currents | |
| ELA 1 | | with multiple ranges of primary currents | |
| ELA 1 | | fast-saturating (FS2) | |
| ELA 2 | diameter 60 mm | | 100 mm |
| ELA 3 | diameter 90 mm | | 130 mm |

Type ELA current transformers technical information:

| | |
|---|--|
| Nominal primary current | $I_{np} = 1 \div 2500 \text{ A}$ |
| Nominal continuous thermal current | $I_{pn} = \text{ext. } 120\% \text{, up to } 200\% \text{ on request}$ |
| Nominal secondary current | $I_{sn} = 5 \text{ A or } 1 \text{ A}$ |
| Nominal load | $S_{2n} = 0,5 \text{ VA} \div 40 \text{ VA}$ |
| Accuracy class | 0,2; 0,5; 1; 3; 5 class 0.2 and 0.5 CT's can be verified as measuring instruments |
| Nominal instantaneous thermal current 1 s | $I_{th} = 60 \times I_{pn}$ |
| Nominal dynamic current | $I_{dn} = 2,5 \times I_{th}$ |
| Nominal frequency | $f = 50 \div 60 \text{ Hz}$ |
| Highest permissible voltage | $U_n = 0,72 \text{ kV or } 1,2 \text{ kV}$ |
| Nominal test voltage | $U_p = 3 \text{ kV or } 6 \text{ kV}$ |

– **series ISN current transformers** mounted directly onto busbar. An ISN CT slides onto a busbar and gets fixed in place by tightening of the fitting screws.

| Type | Aperture size | Notes | CT width |
|---------------------------|--|--|----------|
| ISN 0 | 20 x 6 mm | | 40 mm |
| ISN 1 | 20 x 10; 30 x 10 or 40 x 10 mm | | 60 mm |
| ISN 1 | 20 x 10 or 30 x 10 mm | with secondary winding connections led out | 60 mm |
| ISN 2 | 40 x 10; 50 x 10; 60x 10 or 2 x 60 x 10 mm | | 80 mm |
| ISN 2 | 40 x 10; 50 x 10 or 60 x 10 mm | with dual primary range | 80 mm |
| ISN 3 | 60 x 10; 80 x 10 or 2 x 60 x 10; 2 x 80 x 10 mm | | 100 mm |
| ISN 30 | 40 x 10; 50 x 10; 60 x 10 or 2 x 40 x 10; 2 x 50 x 10; 2 x 60 x 10 mm | | 100 mm |
| ISN 31; 32; 33 | 2 x 80 x 10; 2 x 100 x 10; or 2 x 120 x 10 mm | | 100 mm |
| ISN 4 | 2 x 80 x 10; 2 x 100 x 10; or 3 x 80 x 10; 3 x 100 x 10 mm | | 130 mm |
| ISN 40; 41; 42; 43; 44 | 3 x 60 x 10; 3 x 80 x 10; 3 x 100 x 10; 3 x 120 x 10; 3 x 160 x 10 mm | | 130 mm |

Type ISN current transformers technical information:

| | |
|---|--|
| Nominal primary current | $I_{pn} = 20 \div 7500$ A |
| Nominal continuous thermal current | $I_{pn} = \text{ext. } 120\%$, up to 200% on request |
| Nominal secondary current | $I_{sn} = 5$ A or 1 A |
| Nominal load | $S_{2n} = 0,5$ VA \div 50 VA |
| Accuracy class | 0,2; 0,5; 1; 3; 5 the ISN 1, ISN 2 and ISN 3 CT's in class 0,5 can be verified as measuring instruments |
| Nominal instantaneous thermal current 1 s | $I_{th} = 60 \times I_{pn}$ |
| Nominal dynamic current | depends on a busbar system (practically unlimited) |
| Nominal frequency | $f = 50 \div 60$ Hz |
| Highest permissible voltage | $U_n = 1,2$ kV |
| Nominal test voltage | $U_p = 6$ kV |

2. ABB Zwar's low-voltage current transformers:

– **series IMW, IMP and IMS current transformers** manufactured in primary winding, cable or busbar version depending on the type. The transformers are enclosed in casings made from slow-burning, shock resistant material with transparent cover for sealing the secondary terminals.

| Type | Aperture size | CT width |
|------------------|---------------------------------------|-----------|
| IMW | with primary winding | 77, 50 mm |
| IMP _a | diameter 20,2 mm | 74 mm |
| IMP _b | diameter 30,2 mm | 74 mm |
| IMS _a | 40 x 10 mm | 60 mm |
| IMS _b | 60 x 10 mm | 80 mm |
| IMS _c | 80 x 10 mm | 100 mm |
| IMS _d | 30 x 122; 50 x 102; 86,5 x 86,5 mm | 194 mm |

Type IMW, IMS and IMP current transformers technical information:

| | |
|---|--|
| Nominal primary current | $I_{pn} = 1 \div 1000$ A |
| Nominal secondary current | $I_{sn} = 5$ A or 1 A |
| Accuracy class | 0,2; 0,5; 1 class 0.2 and 0.5 CT's are verified as measuring instruments |
| Nominal instantaneous thermal current 1 s | $I_{th} = 60 \times I_{pn}$ |
| Nominal peak current | $I_{dn} = 150 \times I_{pn}$ |
| Nominal frequency | $f = 50 \div 60$ Hz |
| Highest permissible voltage | $U_m = 0,72$ kV |
| Nominal test voltage | $U_p = 3$ kV |

Standards:

PN – EN 60044 – 1, EN 60044 – 1, VDE 0414/70.

Certified by the Polish Centre for Testing and Certification (PCBC).

Introduction

The transformers are destined for energising of measuring equipment and protection circuits in electric power appliances with nominal voltage from 10 to 24kV and frequency of 50Hz. They are designed to work indoors in moderate or tropical climate conditions.

Construction

The essential components of the transformer are: the primary winding, the core with secondary windings and the base. Primary and secondary windings are submerged in epoxide resin, which is the main insulation and the housing of the transformer. In the terminal compartment of the base there are clamping plates connected to secondary windings. The screws supplied with the transformer allow earthing of individual secondary windings terminals. The terminal compartment is also equipped with Pg 16 sealing glands. The transformer base is provided with a M8 bolt.

Operation principles

Medium-voltage transformer is a low-power transformer working in state similar to idle, which converts high primary voltage into lowered secondary voltage meeting the requirements of an accuracy class. The transformers can work up to 1000 m above sea level, in indoor appliances, at temperatures between -10°C and 55°C, and relative humidity of up to 90%. The lowest allowable storage and transport temperature is -30°C.



Types of medium-voltage transformers:

- **type UMZ 12, UMZ 17 and UMZ 24 voltage transformers** two insulated terminals (poles),
- **type UMZ 12-1, UMZ 17-1 and UMZ 24- 1 voltage transformers** with one insulated terminal (pole).

Manufactured in versions varying in: primary voltage, secondary voltage, power in accuracy class.

Technical parameters

Parameters standard for all type UMZ voltage transformers:
Permissible thermal current for nominal secondary voltages
 $U_{SN}=100(V)$ i $U_{SN}=110 (V)$

- single-pole voltage transformers:
2(A) for the measuring winding, 8 hours, $U = 1,9 \times U_n$
6(A) for the measuring winding, 8 hours, $U = 1,9 \times U_n$
- two-pole voltage transformers:
2(A) continuous, $U = 1,2 \times U_n$

Transformer advantages:

- small dimensions,
- resistant to degrading influence of adverse operating environment,
- the width, position of the primary terminal and mounting holes allow easy replacement of the transformer with products from other brands,
- complies with international standards,
- independently sealable measuring secondary windings.

Standards:

PN – IEC 186,
IEC 186,
VDE 0414,
GOST 1983 – 89

Introduction

The resin insulation current transformers are destined to energise measuring equipment and protection circuits in electric power appliances with allowable network voltage of 24kV and frequency of 50Hz. They are designed to work indoors in moderate, tropical and adverse climate conditions.

Construction

The essential components of the transformer are: the primary coil, the secondary coil(s), the magnetic core and the aluminium alloy base. The primary coil is submerged in epoxide resin making a cast. The epoxide composition is also the main insulation of the transformer. In the aperture in the cast, there are magnetic cores together with secondary windings wound around insulating frames. The alloy plate is fitted to the cast as a support. In the base of the transformer there is a terminal compartment with clamps connected to secondary windings. There are screws supplied in a plastic bag inside the terminal compartment for earthing.

Operation principles

The resin insulation CT's are low-power single-phase transformers working in state similar to short circuit, converting primary current in high-potential circuit into low-potential secondary current meeting accuracy class requirements. They are designed to work in indoor appliances, moderate climate conditions and temperature from 268K (-5°C) to 313K (+40°C).



Types of MV current transformers:

Transformer types:

- ASK 10 A, ASK 10B, ASK 20 A, ASK 20B
- IMZ 10, IMZ 20, IMZ 24

CT advantages:

- small dimensions,
- all assembly measurements allow replacing with well-known brands' CT's,
- reliable operation,
- very low level of partial discharges,
- durable insulation.

CT's technical parameters:

| Type | Highest permissible voltage | Nominal frequency | Alternating test voltage | Impulse test voltage | Maximal current | | Nominal peak current | Nominal current 1 – second |
|--------------|-----------------------------|-------------------|--------------------------|----------------------|-----------------|---------------------|----------------------|---|
| | | | | | 1 – sec. | peak | | |
| | $U_{n \max}$ (kV) | F_n (Hz) | U_{pp} (kV) | U_{pu} (kV) | I_{th} (kA) | $I_{dyn \max}$ (kV) | I_{dyn} (kA) | I_{th} (kA) |
| ASK 10 A i B | 12 | 50 | 28 | 75 | 60 | 150 | $2,5 \times I_{th}$ | $150 \times I_{pn} / 300 \times I_{pn} / 500 \times I_{pn}$ |
| ASK 20 A i B | 24 | 50 | 50 | 125 | 60 | 150 | $2,5 \times I_{th}$ | $150 \times I_{pn} / 300 \times I_{pn} / 500 \times I_{pn}$ |

| Type | Highest permissible voltage | Nominal insulation test voltage | | Nominal frequency | Maximal current | | Nominal peak current | |
|--------|-----------------------------|---------------------------------|------------|-------------------|-----------------|--------------------|----------------------|---------------------|
| | | network frequency | impulse | | 1 – sec. | peak | | |
| | $U_{n \max}$ (kV) | U_n (kV) | U_p (kV) | U_{pp} (kV) | f_n (Hz) | $I_{th \max}$ (kA) | $I_{dyn \max}$ (kV) | I_{dyn} (kA) |
| IMZ 10 | 12 | 10 | 28 | 75 | 50 | 60 | 150 | $2,5 \times I_{th}$ |
| IMZ 20 | 24 | 20 | 50 | 125 | 50 | 60 | 150 | $2,5 \times I_{th}$ |

Standards:

- PN – IEC 185,
- IEC 185,
- DIN/VDE 0414,
- PN – 84/E – 06 552

NOTES

A series of horizontal dotted lines for writing notes.

TWELVE ELECTRIC'S OTHER OFFERS

POWER FACTOR CORRECTION

MRM - 12
power factor regulators



BK - T - 95
capacitor banks



K . 99 / 3
LV power capacitors



DWD - 12
filtering reactors



NETWORK QUALITY MONITORING

- **AS – 3plus**
Network Parameters Analyser with graphical display
- **AS – 3mini**
DIN-mounted Network Parameters Analyser
- **AS – 3energia**
energy costs Analyser with elements of energy quality analysis
- **AS – 3diagnoza**
portable Network Parameter Analysers with set of measuring clamps
- **AS – Multi 2002**
system software for data transfer, visualisation, reports and alarms



Twelve Electric Sp. z o.o.
04 - 987 Warszawa, ul. Wał Miedzeszyński 162
tel. +48 (22) 872 20 20, fax. +48 (22) 612 79 49
skype: t12e_1, t12e_2, t12e_3
e - mail: twelvee@twelvee.com.pl
www.twelvee.com.pl